

INSTRUCTION SHEET

3-HOLE HEAVY DUTY PUNCH NO. 123N

Thank you for choosing the Carl 3-Hole Heavy Duty Punch No. 123N
Please carefully read these instructions before using your punch to obtain best results.
File this instruction sheet safely for future reference.

⚠ Cautions

Injury may occur through mis-use.

- ⚠ DO NOT lower the handle when hand or fingers are beneath the punching blade.
 - ⊘ DO NOT allow small children to use the machine and ensure that it is kept out of reach of children when not in use.
 - ⊘ DO NOT attempt to modify the operations of the machine.
- To ensure that your machine operates effectively:
- ⊘ FOR BEST USE always ensure that the machine is in a stable environment before commencing to punch.
 - ⚠ Only use the Carl 123MD punching blade.
 - ⚠ Ensure that clips and staples are removed from the area to be punched before use.
 - ⚠ Clean out the paper waste tray from time to time.
 - ⚠ Punch should only be used for perforating paper.
 - ⊘ Paper volumes should not be more than specified on the instruction sheet.
 - ⊘ Rotate the punching disk from time to time allowing the blade to punch onto an unused portion of the punching disk
 - ⊘ Once the punching disk has been fully used replace with a new punching disk.

Name of parts

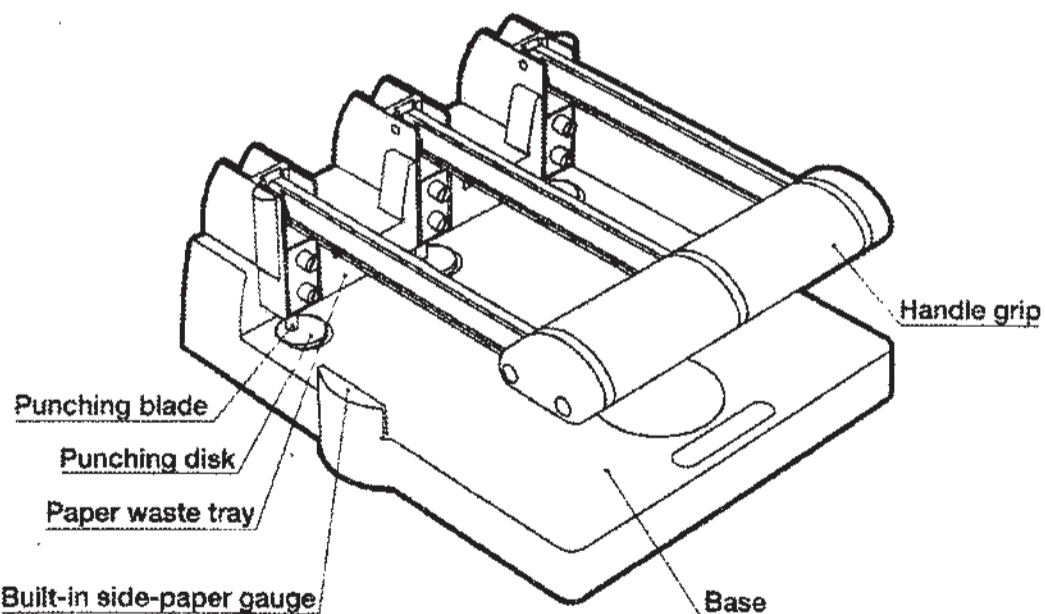

Product Specifications

Punching capacity	150 sheets (15mm) of 80gsm paper
Hole diameter	7 mm
Hole pitch	108 mm
Depth	12 mm
Built-in side-paper gauge	A4 (LTR) Size
Sizes	W307mm x L338mm x H175mm
Weight	4.0kgs

To Use the Punch

- (i) Lift up the handle.
- (ii) Use the built-in side-paper gauge to set the paper punching position.
- (iii) Once papers are set press the handle downward to punch.
Ensure that the punching blade is completely through to the punching disk.
- (iv) Once punching is complete the handle should be lifted to retract the paper.

● To Set the Paper Position

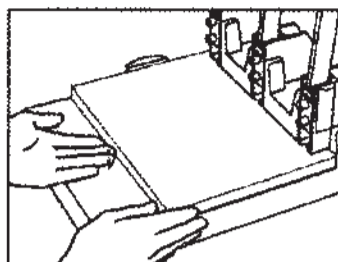

- (i) Place the paper on the base.
- (ii) Align the paper to the left position at the side paper gauge.

⚠ Press the papers firmly to the back wall.

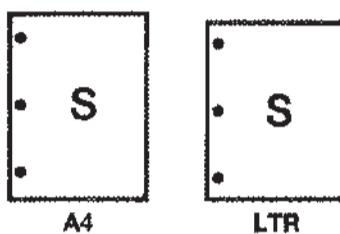

- Punching blade and paper gauge are set for A4 size.
- Punching position for LTR size is indicated on the base.

● Paper Waste

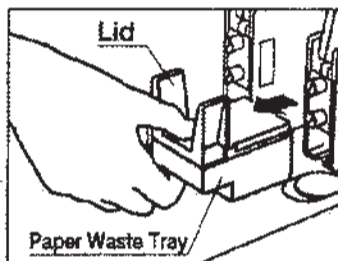

- Pull out the paper waste tray, open the lid and discard the waste.

⚠ The paper waste tray should be cleaned out from time to time.

If blades seem to be dull

● Rotation of the position of punching blades

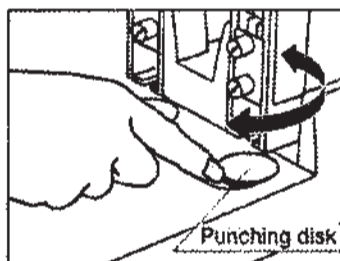

- If you feel blade becomes dull, rotate the punching disk in use from time to time.

⚠ Do not place your hands under blades. (It may result in injury.)

● Replacement of the Punching disk

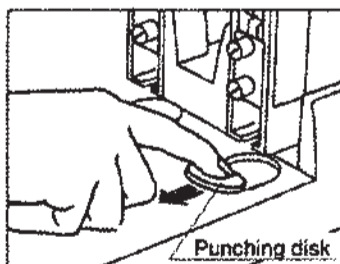

- Once circumference of the punching disk is all damaged, replace the punching disk.

⚠ Do not place your hands under blades. (It may result in injury.)

● Replacement of the punching blades

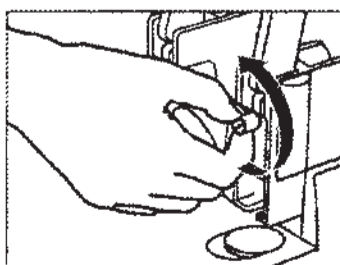

- Once the punching blade has become blunt, it should be replaced.
Turn the screw counter clockwise to expose the punching blade.
Replace the old punching blade with the new one.

⊘ Do not touch the point of the blade. (It may result in injury.)

